



Y50X-0803ZJ10-B Bayonet Stainless Steel 3 Pin Male Front Mount Square Flange Disc Socket

Part Number:

Y50X-0803ZJ10-B

Basic Information

Color	Silver
Connector Type	Socket
Contact Termination	Solder
Contact Type	Male Pin
Fastening Type	Bayonet
Mounting Type	Panel Mount
Number of Positions	3 Pin
Orientation	Straight
Shell Size	8

Material Specification

Contact Finish	Gold Plating
Contact Material	Copper Alloy
Insulation Material	Thermosetting Plastics
Shell Finish	Stainless Steel Passivation
Shell Material	Aluminum Alloy

Environmental Specification

Ingress Protection	IP65
Operating Temperature	-55°C~+125°C

Electrical Specification

Rated Current	5A
Rated Voltage	500V

Contact Layout

03

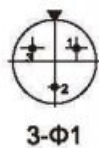

Size

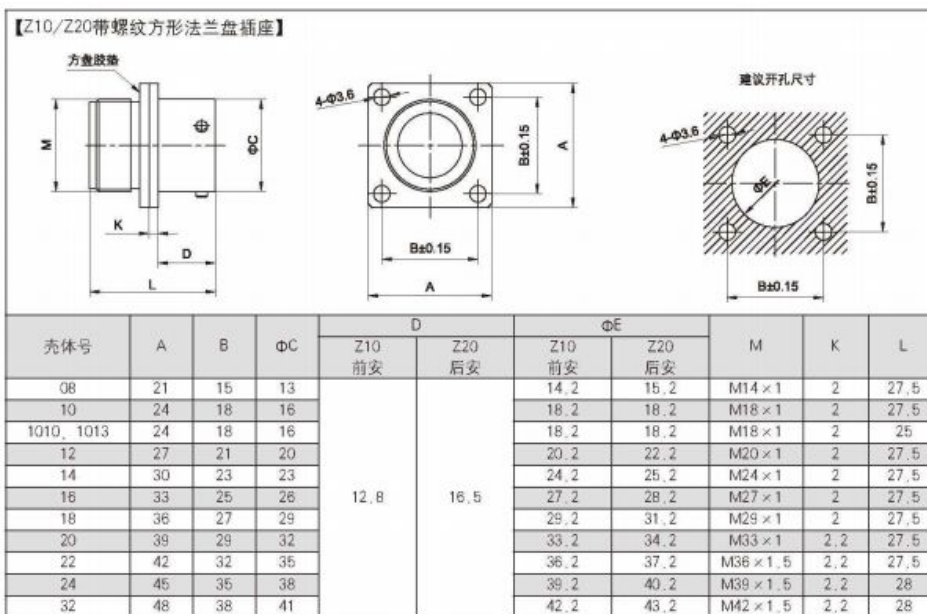

注：0807、0810型号及尺寸见附录1。

How to Order

Part number

	Y50	X	12	-10	T	J	2	III	H	S	L
Basic series											
Type											
X = Solder and hermetic by adhesive P = Solder shielding and hermetic by adhesive A = PCB, solder and hermetic by adhesive C = Hermetic by adhesive without magnetism											
Shell size											
08, 10, 12, 14, 16, 18, 20, 22, 24, 26, 32											
Number of contact											
Z - 61											
Type of connector											
T = Plug Z = Receptacle											
Type of contact											
J = Pin K = Socket SJ = Thru bulkhead Pin SK = Thru bulkhead Socket											
Type of plug and receptacle (See below datasheet I)											
Orientation											
Omit = N N, W, X, Y, Z (See below)											
Finish											
P1 = Electroless nickel plating P2 = Bright nickel plating P3 = Half bright nickel plating H1 = Conductive black L2 = Olive drab cadmium plating H = Black anodized L = Olive drab anodized L1 = Olive drab matte L3 = White anodized											
Material of shell											
S = Cooper-alloy B = Stainless steel passivated Omit = Aluminium-alloy											
Length											

Disclaimer

The information in this specification is subject to change without notice. Please confirm the latest version before use. Technical parameters are for reference only, and sufficient testing and verification should be conducted in actual applications.